

2.2 Compuertas básicas y universales.

Las compuertas básicas fueron nombradas en los postulados del álgebra de Boole; la ley de composición interna suma y multiplicación lógica (OR y AND), y el postulado **V** del elemento opuesto, que trata de la compuerta inversora NOT. Estas compuertas se denominan **básicas** porque, a través de ellas, se pueden desarrollar todos los circuitos digitales de lógica binaria. No obstante, la dificultad que se puede presentar está en los diseños de circuitos digitales grandes que necesitan combinaciones de compuertas básicas para efectuar una función lógica particular. Esta necesidad trajo como consecuencia la creación de otros tipos, llamadas **compuertas universales** que son el resultado de combinaciones de las tres compuertas básicas OR, AND y NOT. Por otra parte, mediante la conexión de compuertas universales, es posible lograr arreglos que funcionen igual a las compuertas básicas.

A continuación, la tabla 2.1 y 2.2, presentan los tipos de compuertas con su respectiva función lógica, símbolo, tabla de la verdad y circuito eléctrico equivalente.

Función lógica	Símbolo	Tabla de la verdad	Circuito eléctrico equivalente															
OR $F(a, b) = a + b$		<table border="1" data-bbox="950 1220 1070 1339"> <thead> <tr> <th>a</th> <th>b</th> <th>F</th> </tr> </thead> <tbody> <tr> <td>0</td> <td>0</td> <td>0</td> </tr> <tr> <td>0</td> <td>1</td> <td>1</td> </tr> <tr> <td>1</td> <td>0</td> <td>1</td> </tr> <tr> <td>1</td> <td>1</td> <td>1</td> </tr> </tbody> </table>	a	b	F	0	0	0	0	1	1	1	0	1	1	1	1	
a	b	F																
0	0	0																
0	1	1																
1	0	1																
1	1	1																
AND $F(a, b) = a \cdot b$		<table border="1" data-bbox="950 1423 1070 1543"> <thead> <tr> <th>a</th> <th>b</th> <th>F</th> </tr> </thead> <tbody> <tr> <td>0</td> <td>0</td> <td>0</td> </tr> <tr> <td>0</td> <td>1</td> <td>0</td> </tr> <tr> <td>1</td> <td>0</td> <td>0</td> </tr> <tr> <td>1</td> <td>1</td> <td>1</td> </tr> </tbody> </table>	a	b	F	0	0	0	0	1	0	1	0	0	1	1	1	
a	b	F																
0	0	0																
0	1	0																
1	0	0																
1	1	1																
NOT $F(a) = \bar{a}$		<table border="1" data-bbox="971 1654 1049 1732"> <thead> <tr> <th>a</th> <th>F</th> </tr> </thead> <tbody> <tr> <td>0</td> <td>1</td> </tr> <tr> <td>1</td> <td>0</td> </tr> </tbody> </table>	a	F	0	1	1	0										
a	F																	
0	1																	
1	0																	

Tabla 2.1. Compuertas básicas y sus circuitos eléctrico y electrónico equivalentes.

Función lógica	Símbolo	Tabla de la verdad	Circuito eléctrico equivalente															
NOR $F(a,b) = \overline{a + b}$		<table border="1" data-bbox="966 457 1084 577"> <thead> <tr> <th>a</th> <th>b</th> <th>F</th> </tr> </thead> <tbody> <tr> <td>0</td> <td>0</td> <td>1</td> </tr> <tr> <td>0</td> <td>1</td> <td>0</td> </tr> <tr> <td>1</td> <td>0</td> <td>0</td> </tr> <tr> <td>1</td> <td>1</td> <td>0</td> </tr> </tbody> </table>	a	b	F	0	0	1	0	1	0	1	0	0	1	1	0	
a	b	F																
0	0	1																
0	1	0																
1	0	0																
1	1	0																
NAND $F(a,b) = \overline{a \cdot b}$		<table border="1" data-bbox="966 661 1084 781"> <thead> <tr> <th>a</th> <th>b</th> <th>F</th> </tr> </thead> <tbody> <tr> <td>0</td> <td>0</td> <td>1</td> </tr> <tr> <td>0</td> <td>1</td> <td>1</td> </tr> <tr> <td>1</td> <td>0</td> <td>1</td> </tr> <tr> <td>1</td> <td>1</td> <td>0</td> </tr> </tbody> </table>	a	b	F	0	0	1	0	1	1	1	0	1	1	1	0	
a	b	F																
0	0	1																
0	1	1																
1	0	1																
1	1	0																
XOR $F(a,b) = \overline{a} \cdot b + a \cdot \overline{b}$ $F(a,b) = a \oplus b$		<table border="1" data-bbox="966 865 1084 984"> <thead> <tr> <th>a</th> <th>b</th> <th>F</th> </tr> </thead> <tbody> <tr> <td>0</td> <td>0</td> <td>0</td> </tr> <tr> <td>0</td> <td>1</td> <td>1</td> </tr> <tr> <td>1</td> <td>0</td> <td>1</td> </tr> <tr> <td>1</td> <td>1</td> <td>0</td> </tr> </tbody> </table>	a	b	F	0	0	0	0	1	1	1	0	1	1	1	0	
a	b	F																
0	0	0																
0	1	1																
1	0	1																
1	1	0																
XNOR $F(a,b) = \overline{a} \cdot \overline{b} + a \cdot b$ $F(a,b) = \overline{a \oplus b}$		<table border="1" data-bbox="966 1123 1084 1243"> <thead> <tr> <th>a</th> <th>b</th> <th>F</th> </tr> </thead> <tbody> <tr> <td>0</td> <td>0</td> <td>1</td> </tr> <tr> <td>0</td> <td>1</td> <td>0</td> </tr> <tr> <td>1</td> <td>0</td> <td>0</td> </tr> <tr> <td>1</td> <td>1</td> <td>1</td> </tr> </tbody> </table>	a	b	F	0	0	1	0	1	0	1	0	0	1	1	1	
a	b	F																
0	0	1																
0	1	0																
1	0	0																
1	1	1																

Tabla 2.2. Compuertas universales y sus circuitos eléctricos y electrónicos equivalentes.

2.2.1 Arreglos equivalentes entre las compuertas universales y básicas.

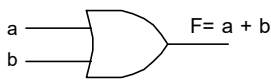
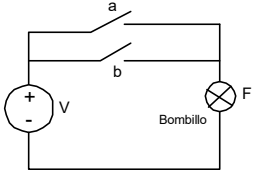
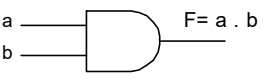
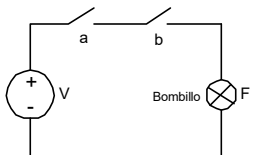
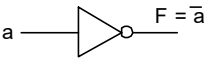
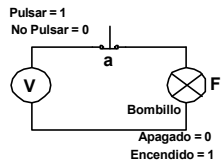
Las compuertas NAND y NOR son universales; esto significa que, realizando arreglos con ellas, se pueden obtener todas las configuraciones de compuertas básicas y también, configuraciones de compuertas XOR y XNOR. Esto está sustentado en el teorema de DeMorgan, los teoremas del álgebra de Boole y el principio de identidad donde la doble negación, de una función, es equivalente a la misma función. Del mismo modo, las variables de una función lógica pueden ser sustituidas por una sola variable equivalente (principio de sustitución), también puede generalizarse para n variables.

$$F(x_1, x_2, \dots, x_n) = \overline{\overline{F(x_1, x_2, \dots, x_n)}} \quad \text{Ec. 2.1}$$

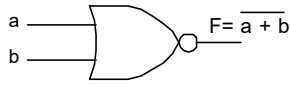
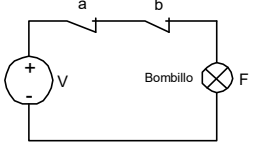
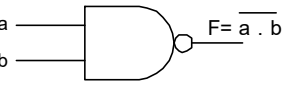
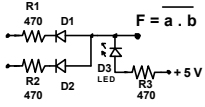
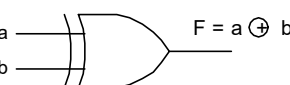
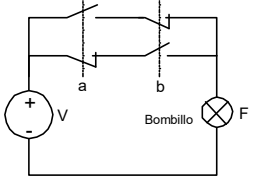
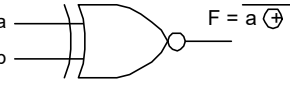
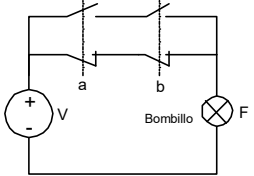
Las tablas 2.3 y 2.4 presentan los circuitos equivalentes de compuertas básicas realizados con NOR y NAND respectivamente.

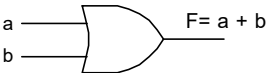
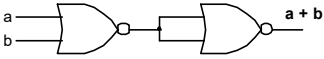
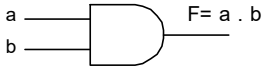
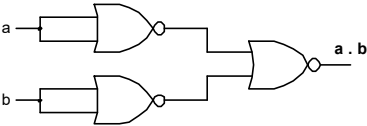
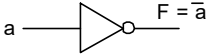
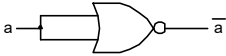
Función lógica	Símbolo	Circuito eléctrico equivalente NOR
OR $F(a,b) = a + b$		
AND $F(a,b) = a \cdot b$		
NOT $F(a) = \bar{a}$		

Tabla 2.3. Circuitos equivalentes OR, AND y NOT realizados con compuertas universales NOR.

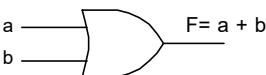
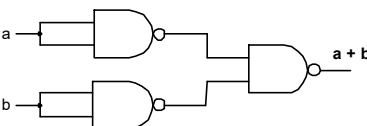
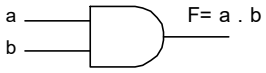
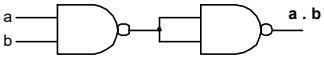
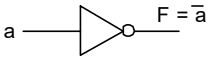
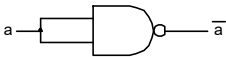
Función lógica	Símbolo	Circuito eléctrico equivalente NAND
OR $F(a,b) = a + b$		
AND $F(a,b) = a \cdot b$		
NOT $F(a) = \bar{a}$		

Tabla 2.4. Circuitos equivalentes OR, AND y NOT realizados con compuertas universales NAND.